

NETZSCH

Proven Excellence.



Dosing Technology

Emptying – Conveying – Dosing

Pumps & Systems

YOU'VE GOT THE APPLICATION,
we've got the solution

As a truly global producer of progressing cavity pumps NETZSCH Pumpen & Systeme GmbH has been developing, manufacturing and selling NEMO® progressing cavity pumps worldwide for more than six decades. These are the heart of the NETZSCH barrel emptying and dosing systems.

Our products are operating, amongst others, in the following industries:

- Food
- Cosmetics
- Chemical industries
- Consumer goods
- Industrial goods
- Electrical equipment
- Electronic components



Product Range

NETZSCH

Barrel Emptying Units

Standard units for the emptying of barrels from 20 l to 200 l. Capacities from approx. 6 ml up to approx. 10 m³/h. Clean emptying, residues <1 % without liner.

NETZSCH Dosing Systems

For best co-ordination/synchronization between emptying and dosing we offer combined barrel emptying unit, control system, buffer storage and dispenser.

NEMO® Dispenser

Capacities from approx. 0.2 ml up to 4,0 ml chamber volume per revolution, dosing accuracy +/- 1 %.

NETZSCH Control Systems

Start/stop control
1K control

NETZSCH Buffer Vessel

Buffer volume approx. 1.0 l; delivers a constant feed pressure for the dispenser to ensure the highest levels of dosing accuracy. Also enables barrel changes without interrupting the production process.

How fortunate to be able to choose

Always orientated around the benefits of the customer, the NETZSCH products range from the smallest dosing pumps with flow rates of a few milliliters to powerful pumps to transfer 1000 m³/h. In addition, we provide macerators and a wide range of accessories. Since we know and understand your process, we provide everything "around the pump" for your application.

Always the right product

NEMO® pumps belong to the group of rotary positive displacement pumps. They consist of two conveying elements, the rotor and the fixed stator, in which the rotor rotates. For each individual application, the most technically suitable pump is chosen. Your advantages are pump types and series, which are ideally matched to your specific application.

We are where you are

With more than 2,000 employees at five development and production sites as well as 30 sales offices, a co-operation partner (in Japan) and another 200 NETZSCH representatives NETZSCH Pumps & Systems is close to you wherever you are.

NETZSCH Barrel Emptying Units

FOR DOSING WITHOUT DRIPPING

Characteristics and Typical Components

NETZSCH barrel emptying units draw themselves towards the bottom of the barrel and empty barrels and containers in chemical, pharmaceutical and food industries with the absolute minimum of product wastage. The heart of the barrel emptying unit is a NEMO® progressing cavity pump. When the pump is started a vacuum is created below the follower plate, which at the same time creates a light pressure on the media to guarantee a consistent suction into the pump. Versions: Frame in stainless steel, other materials optional, mobile or stationary.

Characteristics

- Continuous or intermittent emptying
- No pressure or flow disruptions
- Emptying of conical barrels
- Low pressure conditions in the system
- Continuously adjustable discharge capacity through the speed of the drive
- Dosing directly from the barrel
- Capacity proportionally to the speed of the drive
- Equipped with frequency inverter for easy adjustment
- Simple linear guide rail

Characteristics of Media

- Low to very high viscosity
- Dilatant, thixotropic or having a viscous structure
- Shear and pressure sensitive media
- Highly abrasive media
- Media up to 5 mio cPs are pumpable

Large Range of Capacities

- Capacities from approx. 6 ml/min to 10 m³/h

Barrel Sizes

- Barrels between 20 l to 200 l as standard



The follower plate, with soft lip sealing, presses tightly against the wall of the barrel ensuring almost complete emptying of the container.



The linear guide rail system, used to adjust the height of the pump, can be easily cleaned and accommodates various container sizes.



The standard control panel with frequency inverter is conveniently located, and allows for user-friendly adjustment of product delivery.

Advantages

- Gentle conveyance
- Low pulsation
- Significantly lower shear rate than other pump technologies
- Smooth transport of media with solids
- Conveyance independent of temperature and viscosity
- Complete discharge, residues < 1 %
- Easy maintenance
- Low life cycle cost
- Stainless steel, easy to clean



NBE 200



NBE 20

NETZSCH NBE 20 Barrel Emptying Unit

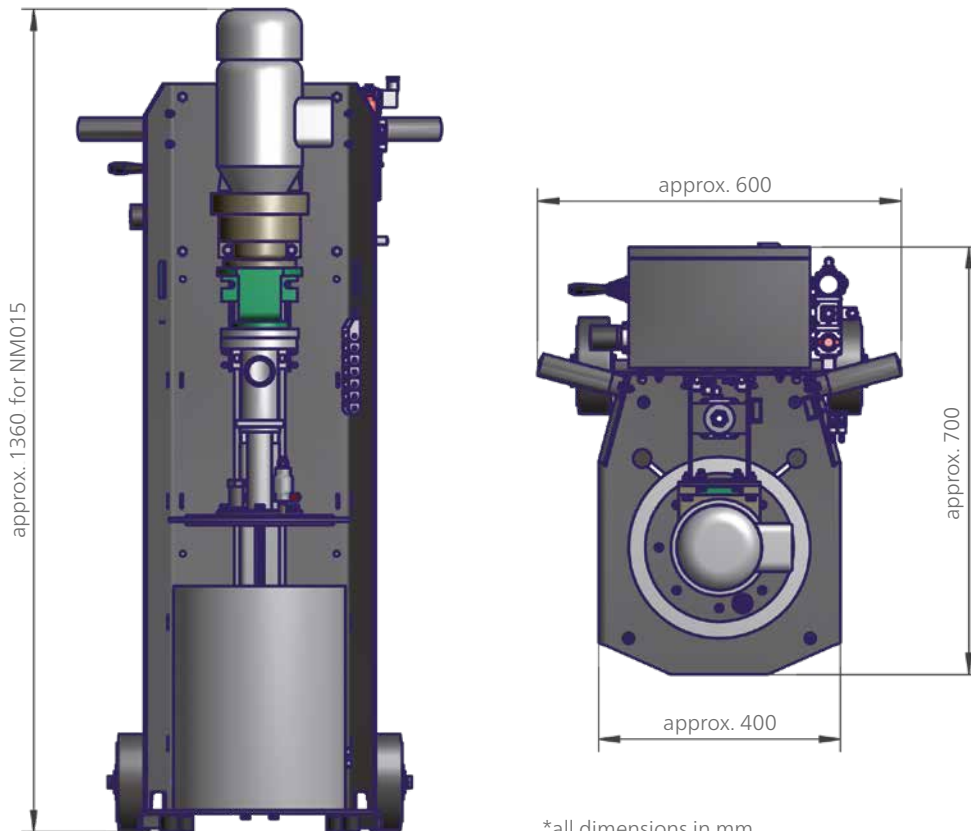

NETZSCH NBE 20 Barrel Emptying Unit

Base frame	Stainless steel
Frame options	Fixed or mobile version
Material in contact with product	1.4571/stainless steel 316
Barrel sizes	20 l standard, others on request
Wiping ring	NBR, EPDM, Viton, (FDA Grades available)
Flow rate	Up to 900 l/h*
Pump	BY industrial pump, BH hygienic pump, sizes up to NM021
Max. back pressure	Up to 290 psi/20 bar*, others on request
Control	Standard with VSD control panel (IP 65)
Optional	PLC dosing control unit available

*depending on the product

NETZSCH NBE 200 Barrel Emptying Unit

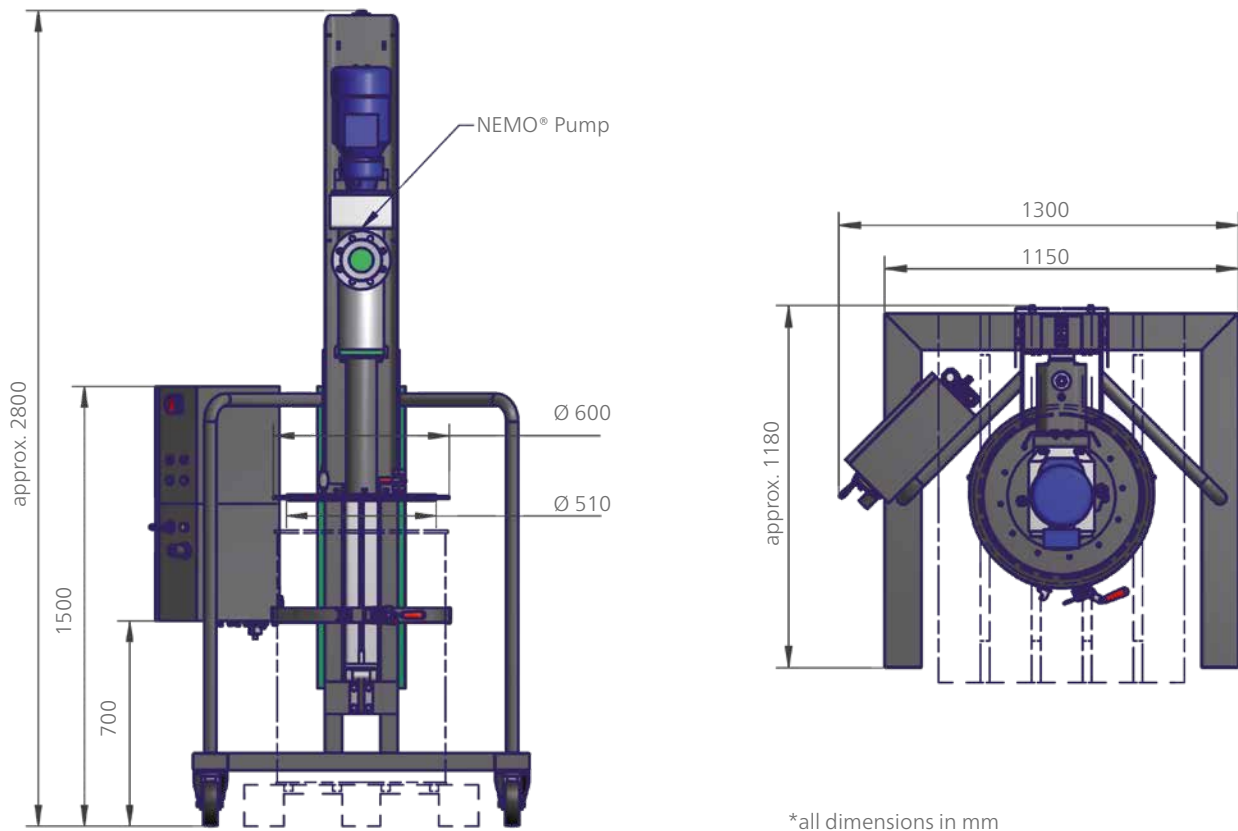

NETZSCH NBE 200 Barrel Emptying Unit

Base frame	Stainless steel
Frame options	Fixed or mobile version
Material in contact with product	1.4571
Barrel sizes	200 l standard, others on request
Wiping ring	NBR, EPDM, Viton, (FDA Grades available)
Flow rate	Up to 10 m ³ /h*
Pump	BY industrial pump, BH sanitary pump, sizes up to NM063
Max. back pressure	Up to 290 psi/20 bar*, others on request
Control	Standard with VSD control panel (IP 65)
Optional	PLC dosing control unit available

*depending on the product

NEMO® Dispenser

FOR THE HIGHEST DOSING ACCURACY

Characteristics and Typical Components

NEMO® dispensers guarantee very precise dosing and high repeatability. As a result of these qualities NEMO® dispensers are being used for various applications in the cosmetic industry, in the chemical industry, in the production of consumer goods or industrial goods, electrical equipment or electronic packaging.

NEMO® Dispenser Characteristics

- Capacity proportional to the speed of drive
- Dosing accuracy $\pm 1\%$ volumetric
- Versatile use in applications that require robotics and servo technology
- Valve free dosing method
- Optional heating
- Perfect for shear sensitive products, such as media with micro balloons

Media Characteristics

- Low to very high viscosity
- Abrasive media
- Anaerobic media
- Shear and pressure sensitive media
- Dot- and bead application
- Suitable for all adhesives and sealants
- Excellent for casting applications
- Suitable for all kinds of solvents and soldering paste

Large Range of Capacities

- Capacities between approx. 2 to 800 ml/min



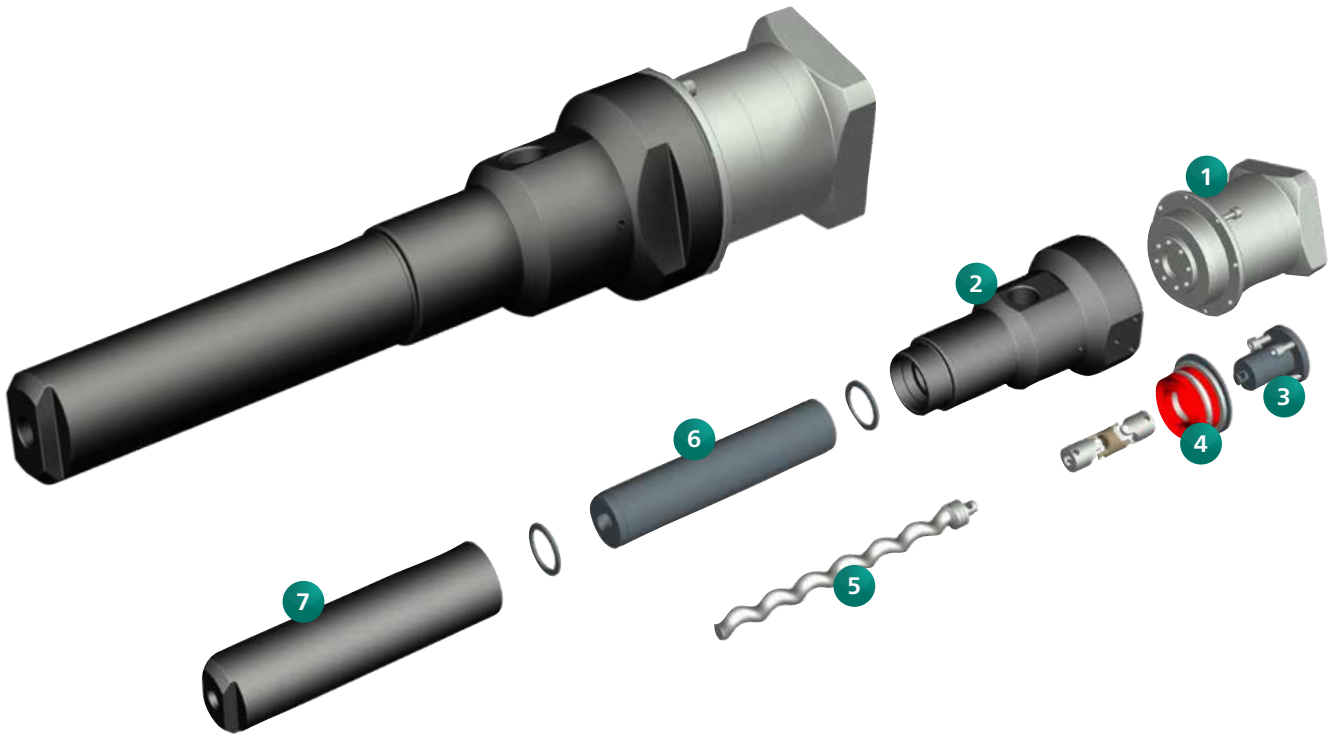

1 Drive

Planetary gear with re-inforced bearing

2 Pump Housing

Manufactured from aluminium

3 Drive Shaft

With robust bearing for precise true-running of shaft

4 Shaft Sealing

Twin lip seal for highest vacuum pressure load

5 Rotor

In wear and corrosion resistant versions

6 Stator

In various qualities for highest durability and abrasion resistance

7 End Connection

Manufactured from aluminium

Advantages

- Very gentle conveyance
- Low pulsation
- Compact design for easy installation in robotic application
- Gentle conveyance of media containing solids
- No dripping or thread-pulling
- Conveyance is independent of temperature and viscosity

NEMO[®] Dispenser NDP0400-04

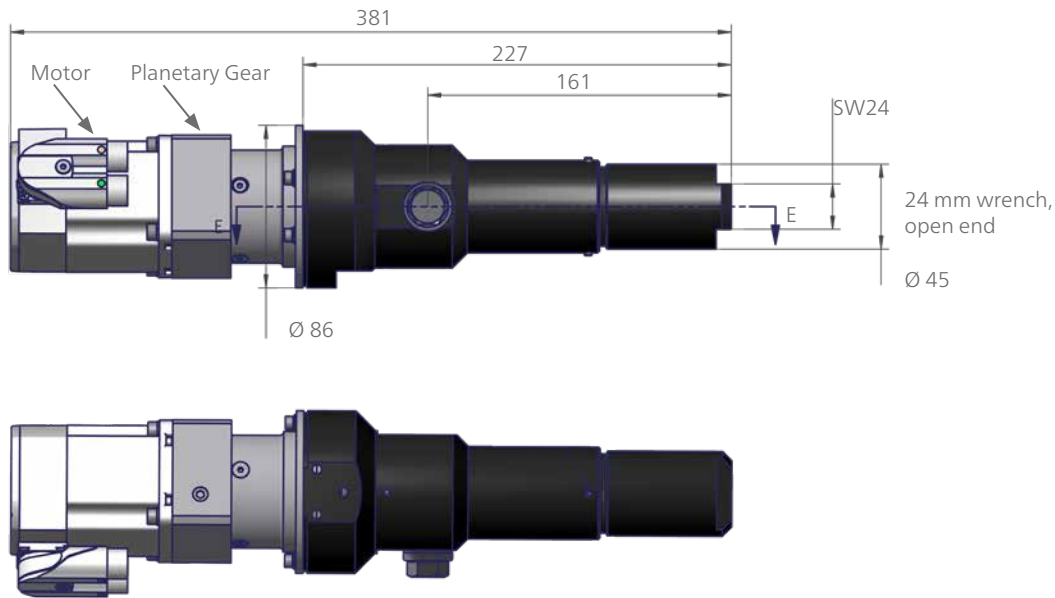

*all dimensions in mm

NEMO[®] Dispenser NDP0400-04

Dosing volume	~ 0.18 ml/rev.
Min. dosing quantity	0.075 ml*
Stator materials	NBR, EPDM, Viton, PTFE 25% GF, (FDA Grades available)
Flow rate	2 - 36 ml/min*
Max. dispense speed	200 rpm*
Operating temperature	up to +248 °F/+120 °C
Max. back pressure	up to 450 psi/30 bar*
Max. inlet pressure	145 psi/10 bar
Weight incl. gearbox	approx. 5.9 lbs/2.7 kg

*depending on product

NEMO® Dispenser NDP0600-03

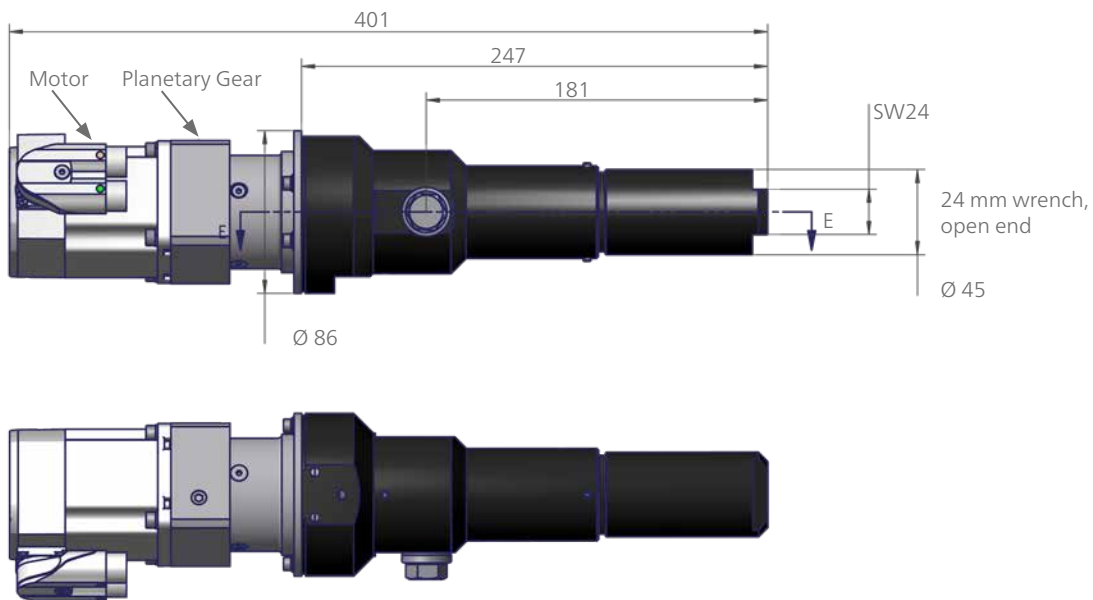

*all dimensions in mm

NEMO® Dispenser NDP0600-03

Dosing volume	~ 1 ml/rev.
Min. dosing quantity	0,25 ml*
Stator materials	NBR, EPDM, Viton, PTFE 25% GF, (FDA Grades available)
Flow rate	6 - 200 ml/min*
Max. dispense speed	200 rpm*
Operating temperature	up to +248 °F/+120 °C
Max. back pressure	up to 450 psi/30 bar*
Max. inlet pressure	145 psi/10 bar
Weight incl. gearbox	approx. 6.2 lbs/2.8 kg

*depending on product

NEMO[®] Dispenser NDP0800-03

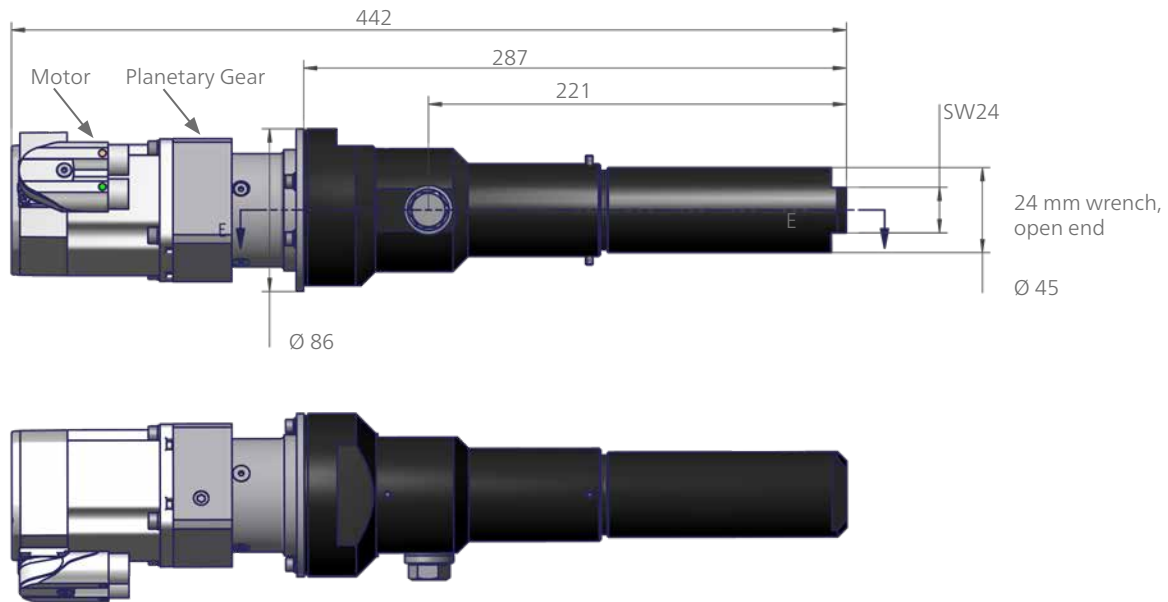

*all dimensions in mm

NEMO[®] Dispenser NDP0800-03

Dosing volume	~ 2 ml/rev.
Min. dosing quantity	0,5 ml*
Stator materials	NBR, EPDM, Viton, PTFE 25% GF, (FDA Grades available)
Flow rate	13 - 400 ml/min*
Max. dispense speed	200 rpm*
Operating temperature	up to +248 °F/+120 °C
Max. back pressure	up to 450 psi/30 bar*
Max. inlet pressure	145 psi/10 bar
Weight incl. gearbox	approx. 6.6 lbs/3 kg

*depending on product

NEMO® Dispenser NDP1000-03



*all dimensions in mm

NEMO® Dispenser NDP1000-03

Dosing volume	~ 4 ml/rev.
Min. dosing quantity	1 ml*
Stator materials	NBR, EPDM, Viton, PTFE 25% GF, (FDA Grades available)
Flow rate	26 - 800 ml/min*
Max. dispense speed	200 rpm*
Operating temperature	up to +248 °F/+120 °C
Max. back pressure	up to 450 psi/30 bar*
Max. inlet pressure	145 psi/10 bar
Weight incl. gearbox	approx. 7.2 lbs/3.3 kg

*depending on product

NETZSCH Dosing Systems

FLEXIBILITY THROUGH MODULAR DESIGN

As a complete dosing solution we offer you an optimally co-ordinated dosing system consisting of a barrel emptying unit, control system, buffer storage and a variety of application units.

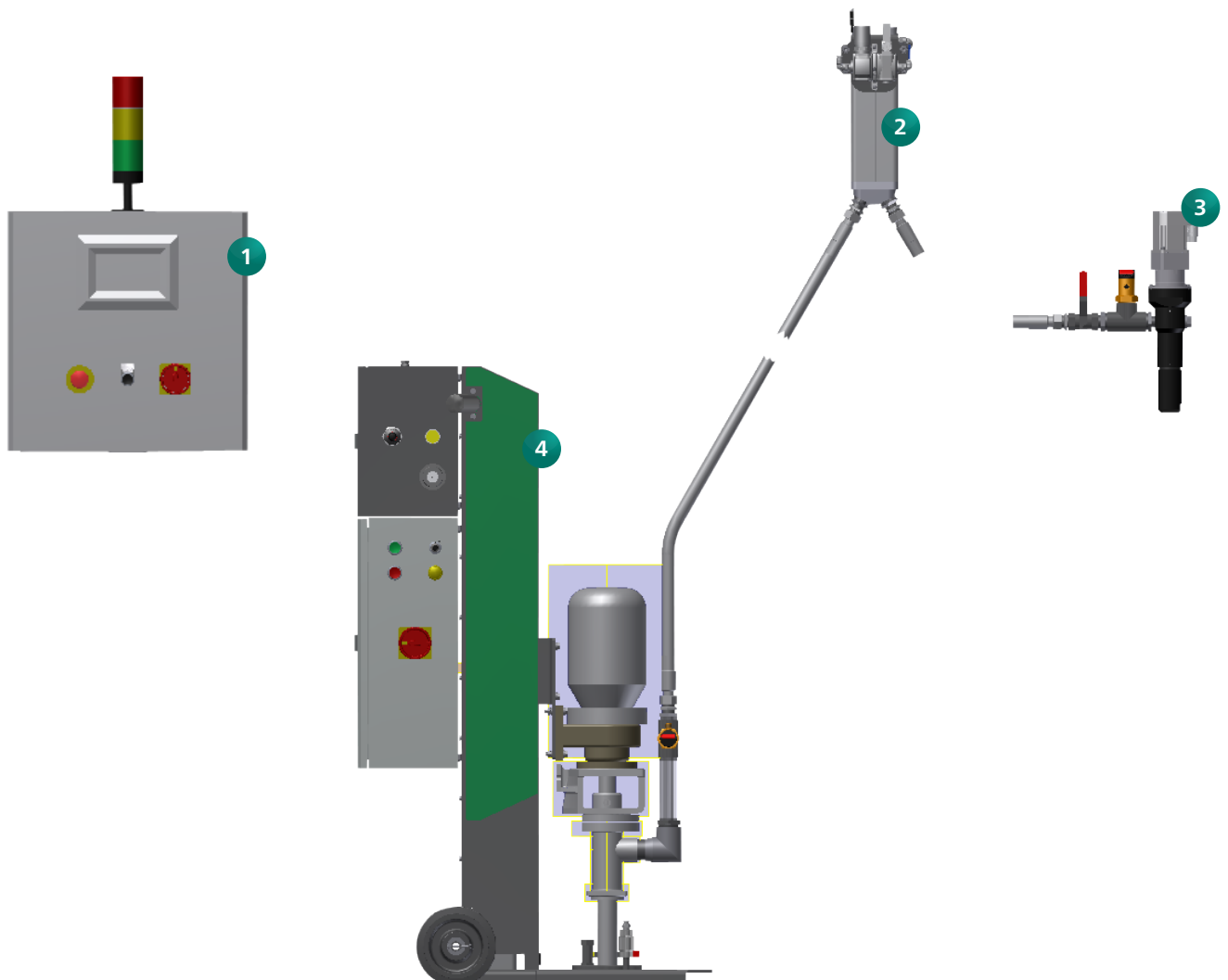

1 Dosing Control

a) Visualisation

Simple, clear user screen with touch panel, complete with mimic diagram of the plant, displaying all important process parameters at a glance. Error message as clear text. User interface in English or German, other languages on request.

b) Installation

Available in all common installation types such as free standing and wall mounted control cabinets as well as console units.

c) Parameterisation

The servo controller parameters of the dispensers can be set via a touch panel, no additional software is required. Simple switching between the various control parameters.

2 Buffer Storage

The buffer storage vessel provides a constant pressure on the suction port of the dispenser to achieve the highest metering accuracy. It compensates for any pressure fluctuations and also allows a change of barrel without interrupting the process. The buffer storage volume is approx. 1.0 l.

3 Dispenser

Dispenser for highest dosing accuracy, details see p. 8 and p. 13

4 Barrel Emptying Unit

Dosing systems are available for barrel emptying units in various sizes, details see p. 4 and p. 7.





The NETZSCH Group is a mid-sized, family-owned German company engaging in the manufacture of machinery and instrumentation with worldwide production, sales, and service branches.

The three Business Units – Analyzing & Testing, Grinding & Dispersing and Pumps & Systems – provide tailored solutions for highest-level needs. Over 3,500 employees at 210 sales and production centers in 35 countries across the globe guarantee that expert service is never far from our customers.

The NETZSCH Business Unit Pumps & Systems offers with NEMO® progressing cavity pumps, TORNADO® rotary lobe pumps, NOTOS® multi screw pumps, macerators/grinders, dosing technology and equipment custom built and challenging solutions for different applications on a global basis.

Proven Excellence.■

NETZSCH Pumpen & Systeme GmbH
Business Field Chemical and Pulp & Paper
Geretsrieder Straße 1
84478 Waldkraiburg
Germany
Tel.: +49 8638 63-1020
Fax: +49 8638 63-2327
info.nps@netzsch.com

NETZSCH®

www.netzsch.com